

## **IR Remote Controlled Water Robot Using ARM7**

**P. VIKRAMSINGH<sup>1</sup>, M. A. KHADAR BABA<sup>2</sup>**

<sup>1</sup>PG Scholar in the Department of Electronics and Communication Engineering, CMR College of Engineering & Technology, Hyderabad, AP-INDIA, E-mail: singh4b9@gmail.com.

<sup>2</sup>Prof in the Department of Electronics and Communication Engineering, CMR College of Engineering & Technology, Hyderabad, AP-INDIA.

**Abstract:** This project is implemented for navigation. This robot is operated by IR remote, where we can change the directions of robot by observing the surroundings using webcam. This robot can be moved using geared motors in the water. This system can be performed by controller ARM7 and IR remote.

**Keywords:** IR, ARM7, Webcam.

### **I. INTRODUCTION**

Now-a-days different kinds of robots are available in market. Robots such as moving on land, climbing a pole, Land-based wheeled robot, Land-based tracked robot, Land-based legged robot, Air-based: plane, helicopter, blimp etc., one such implementation is robot moving on water. In this project a small robot which can move on water with various directions is designed and constructed. Its movements can be controlled by a universal remote control from a distance of ten feet. The robot able to move forward and reverse directions with different directions and it can rotate to the left and right direction. The robot is constructed by using precision DC motor and the control instructions are written by an Embedded C language and preinstalled in a controller. The motor is switched by an H-Bridge of transistors, controlled by the LPC2148 which acts a controller this project is a prototype boat that can travel in water. This robot is powered by 9V rechargeable battery. The direction of the robot can be controlled by an IR remote. This can be moved forward and reverse direction using geared motors of 60RPM. Also this robot can take sharp turnings towards left and right directions. This project uses LPC2148 MCU as its controller. This robot works with IR transmission – reception principle.

In this project, L293D H-Bridge is used to drive the geared DC motor. The Device is a monolithic integrated high voltage, high current four channel driver designed to accept standard DTL or TTL logic levels and drive inductive loads (such as relays solenoids, DC and stepping motors) and switching power transistors.

To simplify use as two bridges each pair of channels is equipped with an enable input. A separate supply input is provided for the logic, allowing operation at a lower voltage and internal clamp diodes are included. The LPC2148 are based on a 16/32 bit ARM7TDMI-S™ CPU with real-time emulation and embedded trace support, together with 128/512 kilobytes of embedded high speed flash memory. A 128-bit wide memory interface and unique accelerator architecture enable 32-bit code execution at maximum clock rate. For critical code size applications, the alternative 16-bit Thumb Mode reduces code by more than 30% with minimal performance penalty.

### **II. RELATED WORK**

#### **A. IR SENSOR**

Sensors are a new solution for measuring currents and voltages needed for protection and monitoring in medium voltage power systems. Certain strong trends have been present during the whole period of electrical equipment manufacturing: a continuous reduction of equipment size, a continuous improvement of equipment performance and a continuously growing need for standardization. However, in some types of equipment the visible effect of those trends has, during long periods of time, been relatively small. A typical example is the transformer, including instrument transformers. The natural properties of the soft iron core, as maximal flux density and lack of linearity in the excitation curve, have set limits for the possibilities to reduce the transformer size and to use the transformer in a wider range of applications. As a consequence, most instrument transformer units have been electrically tailor-made for one certain application and a far-reaching standardization has never been realized. This inconvenience can be defeated with the introduction of sensors based on alternative principles like the Rogowski coil and resistive or capacitive dividers for current and voltage sensing respectively. These principles are far from new; they are generally as old as the sensor principles of conventional inductive instrument transformers.

**Copyright © 2013 International Industrial Scientific Engineering Corporation (IISRC). All rights reserved.**

**International Conference on Industrial Scientific Research Engineering**

**Conference No.03, September-2013, Pages:165-168**

IR device emits and/or detects infrared radiation to sense a particular phase in the environment. Generally, thermal radiation is emitted by all the objects in the infrared spectrum. The infrared sensor detects this type of radiation which is not visible to human eye. The following figure 1 depicts the block diagram of IR sensor.

**1. Advantages:**

- Easy for interfacing
- Readily available in market

**2. Disadvantages:**

- Disturbed by noises in the surrounding such as radiations, ambient light etc. Working the basic idea is to make use of IR LEDs to send the infrared waves to the object. Another IR diode of the same type is to be used to detect the reflected wave from the object. The diagram is shown below.

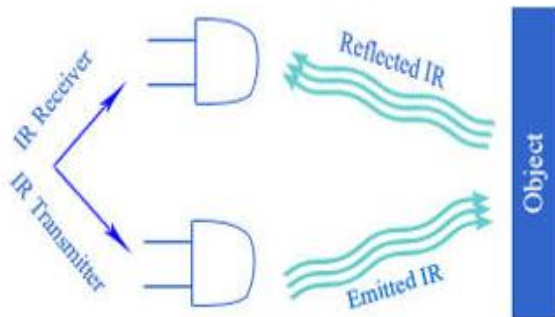

Fig1: Block diagram of IR sensor working

When IR receiver is subjected to infrared light, a voltage difference is produced across the leads. Less voltage which is produced can be hardly detected and hence operational amplifiers (Op-amps) are used to detect the low voltages accurately. Measuring the distance of the object from the receiver sensor: The electrical property of IR sensor components can be used to measure the distance of an object. The fact when IR receiver is subjected to light, a potential difference is produced across the leads.

**B. ARM7**

The LPC2101/02/03 microcontrollers are based on a 16-bit/32-bit ARM7TDMI-S CPU with real-time emulation that combines the microcontroller with 8 kB, 16 kB, or 32 kB of embedded high speed flash memory. A 128-bit wide memory interface and unique accelerator architecture enable 32-bit code execution at the maximum clock rate. For critical performance in interrupt service routines and DSP algorithms, this increases performance up to 30 % over the Thumb mode. For critical code size applications, the alternative 16-bit Thumb mode reduces code by more than 30 % with minimal performance penalty. Due to their tiny size and low power consumption, LPC2101/02/03 are

ideal for applications where miniaturization is a key requirement, such as access control and point-of-sale. A blend of serial communications interfaces, ranging from multiple UARTS, SPI, and SSP to two I2Cs, and on-chip SRAM of 2/4/8 kB make these devices very well suited for communication gateways and protocol converters. The superior performance also makes these devices suitable as math coprocessors. Various 32-bit and 16-bit timers, an improved 10-bit ADC, PWM features through output match on all timers, and 32 fast GPIO lines with up to 13 edge or level sensitive external interrupt pins make these microcontrollers particularly suitable for industrial control and medical systems.

The ARM7TDMI-S is a general purpose 32-bit microprocessor, which offers high performance and very low power consumption. The ARM architecture is based on Reduced Instruction Set Computer (RISC) principles, and the instruction set and related decode mechanism are much simpler than those of micro programmed Complex Instruction Set Computers. This simplicity results in a high instruction throughput and impressive real-time interrupt response from a small and cost-effective processor core. Pipeline techniques are employed so that all parts of the processing and memory systems can operate continuously. Typically, while one instruction is being executed, its successor is being decoded, and a third instruction is being fetched from memory. The ARM7TDMI-S processor also employs a unique architectural strategy known as THUMB, which makes it ideally suited to high-volume applications with memory restrictions, or applications where code density is an issue. The key idea behind THUMB is that of a super-reduced instruction set. Essentially, the ARM7TDMI-S processor has two instruction sets:

- The standard 32-bit ARM instruction set.
- A 16-bit THUMB instruction set.

The THUMB set's 16-bit instruction length allows it to approach twice the density of standard ARM code while retaining most of the ARM's performance advantage over a traditional 16-bit processor using 16-bit registers. This is possible because THUMB code operates on the same 32-bit register set as ARM code. THUMB code is able to provide up to 65% of the code size of ARM, and 160% of the performance of an equivalent ARM processor connected to a 16-bit memory system. The ARM7TDMI-S processor is described in detail in the ARM7TDMI-S data sheet that can be found on official ARM website. The LPC2101/02/03 incorporates a 8kB, 16kB, and 32kB flash memory system respectively. This memory may be used for both code and data storage. Programming of the flash memory may be accomplished in several ways:

## IR Remote Controlled Water Robot Using ARM7

- Using the serial built-in JTAG interface.
- Using In System Programming (ISP) and UART.

### C. FEATURES

1. 16-bit/32-bit ARM7TDMI-S microcontroller in a tiny LQFP48 package.
2. 2kB/4kB/8kB of on-chip static RAM and 8Kb/16kB/32kB of on-chip flash program memory. 128-bit wide interface/accelerator enables high-speed 70 MHz operation. In-System/In-Application Programming (ISP/IAP) via on-chip boot loader software. Single flash sector or full chip erase in 100 ms and programming of 256 bytes in 1 ms.
3. Embedded ICE RT offers real-time debugging with the on-chip Real Monitor software.
4. The 10-bit A/D converter provides eight analog inputs, with conversion times as low as 2.44  $\mu$ s per channel, and dedicated result registers to minimize interrupt overhead.
5. Two 32-bit timers/external event counters with combined seven capture and seven compare channels.
6. Two 16-bit timers/external event counters with combined three capture and seven compare channels.
7. Low power Real-Time Clock (RTC) with independent power and dedicated 32 kHz clock input.
8. Multiple serial interfaces including two UARTs (16C550), two Fast I2C-buses (400 kbit/s), SPI and SSP with buffering and variable data length capabilities.
9. Vectored interrupt controller with configurable priorities and vector addresses.
10. Up to thirty-two 5 V tolerant fast general purpose I/O pins.
11. Up to 13 edge or level sensitive external interrupt pins available.
12. 70 MHz maximum CPU clock available from programmable on-chip PLL with a possible input frequency of 10 MHz to 25 MHz and a settling time of 100  $\mu$ s.
13. On-chip integrated oscillator operates with an external crystal in the range from 1 MHz to 25 MHz.
14. Power saving modes include idle mode, Power-down mode, and Power-down mode with RTC active.
15. Individual enable/disable of peripheral functions as well as peripheral clock scaling for additional power optimization.
16. Processor wake-up from Power-down mode via external interrupt or RTC.

### III. SYSTEM IMPLEMENTATION

In this project a small robot which can move on water with various directions is designed and constructed. Its movements can be controlled by a

universal remote control from a distance of ten feet. The robot able to move forward and reverse directions with different directions and it can rotate to the left and right direction. The robot is constructed by using precision DC motor and the control instructions are written by a Embedded C language and preinstalled in a controller. The motor is switched by an H-Bridge of transistors, controlled by theLPC2148 which acts a controller this project is a prototype boat that can travel in water. This robot is powered by 9V rechargeable battery. The direction of the robot can be controlled by an IR remote. This can be moved forward and reverse direction using geared motors of 60RPM. Also this robot can take sharp turnings towards left and right directions. This project uses LPC2148 MCU as its controller. This robot works with IR transmission – reception principle. Fig 2 gives the brief view if our system.

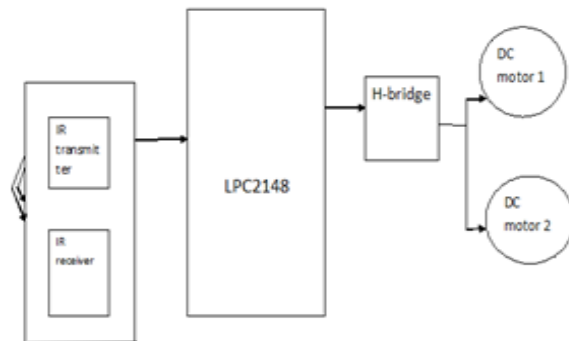

Fig2: Block diagram of the system

In this project, L293D H-Bridge is used to drive the geared DC motor. The Device is a monolithic integrated high voltage, high current four channel driver designed to accept standard DTL or TTL logic levels and drive inductive loads (such as relays solenoids, DC and stepping motors) and switching power transistors. To simplify use as two bridges each pair of channels is equipped with an enable input. A separate supply input is provided for the logic, allowing operation at a lower voltage and internal clamp diodes are included. The LPC2148 are based on a 16/32 bit ARM7TDMI-S™ CPU with real-time emulation and embedded trace support, together with 128/512 kilobytes of embedded high speed flash memory. A 128-bit wide memory interface and unique accelerator architecture enable 32-bit code execution at maximum clock rate. For critical code size applications, the alternative 16-bit Thumb Mode reduces code by more than 30% with minimal performance penalty.

### IV. CONCLUSION

This project is implemented successfully with the help of ARM7 controller and IR sensor. In future this project can be extended by using GPS and GSM for knowing the location.

V. REFERENCES

- [1] H. Asoh, S.Hayamizu, I.Hara, Y. Motomura, S. Akaho, and T. Matsui. Socially embedded learning of oco-conversant robot jijo-2. In Proceedings of IJCAI-97.IJCAI, Inc., 1997.
- [2] H-J. Boehme, A. Brakensiek, U.-D. Braumann, M. Krabbes, and H.-M. Gross. Neural networks for gesture-based remote control of a mobile robot. In Proc. 1998 IEEE World Congress on Computational Intelligence WCCI'98 - IJCNN'98, pages 372{377, Anchorage, 1998. IEEE Computer Society Press.
- [3] H-J. Boehme, U.-D. Braumann, A. Brakensiek, A. Corradini, M. Krabbes, and H.-M. Gross. User localisation for visually-based human-machine interaction. In Proc. 1998 IEEE Int. Conf. on Face and Gesture Recognition, pages 486{491, Nara, Japan, 1998.
- [4] J. Borenstein, B. Everett, and L. Feng. Navigating Mobile Robots: Systems and Techniques. A. K. Peters, Ltd., Wellesley, MA, 1996.
- [5] W. Burgard, A.B. Cremers, D. Fox, D. H□ahnel, G. Lakemeyer, D. Schulz, W. Steiner, and S. Thrun. Experiences with an interactive museum tour-guide robot. Artificial Intelligence, 1999. to appear.
- [6] W. Campbell, A. Becker, A. Azarbayejani, A. Bobick, and A. Pentland. Invariant features for 3-d gesture recognition. Technical Report 379, M.I.T. Media Laboratory, Perceptual Computing Section, 1996.
- [7] I.J.Cox and G.T. Wilfong, editors. Autonomous Robot Vehicles. Springer Verlag, Berlin, 1990.
- [8] J.L.Crowley. Vision for man-machine interaction. Robotics and Autonomous Systems, 19:347{358, 1997}.